

R2A2

CONTENTS

INTRODUCTION.....	2
IMPORTANT SAFETY INSTRUCTIONS.....	3
NOMENCLATURE	6
TECHNICAL DATA	7
PREPARATION BEFORE USE ...	8
OPERATING THE AIR RIVETER...10	
MAINTENANCE	11
STORAGE	15
ORDERING PARTS	15
EXPLODED VIEW	16
PARTS LIST	17
TROUBLESHOOTING	18

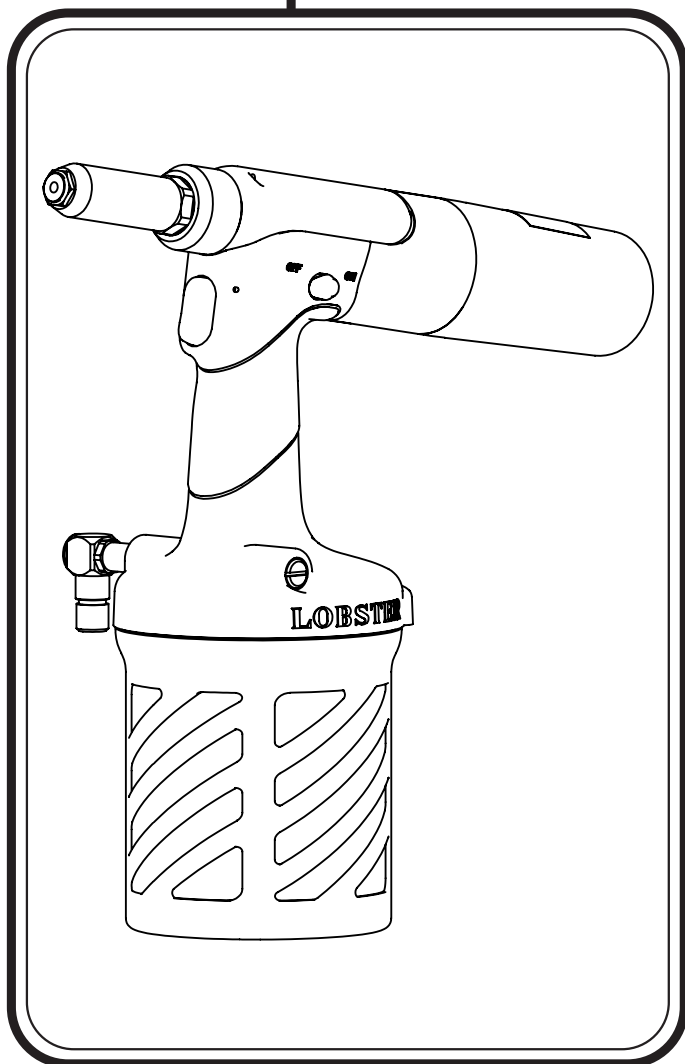

Professional model of air riveter to install blind rivets.

- Thank you very much for purchasing “LOBSTER” air riveter. To ensure correct operation, please read this instruction manual carefully, and keep it in a safe place for later reference.
- This is Original instructions. (Original Instruction Manual is written in English language.)

MANUFACTURER
LOBTEX CO.,LTD.

International Marketing&Sales Division

12-8 Shijo-cho, Higashi-Osaka City
Osaka 579-8053, Japan

Telephone: +81(72)981-7466 Telefac: +81(72)981-9420

URL <https://www.lobtex.co.jp/>

No.RAR2A2S90131

● INTRODUCTION

Thank you very much for purchasing “LOBSTER” air riveter.

- These are the blind rivet tools which is only used for fixing blind rivets. These tools are not designed for other purposes.
- This instruction manual shows how to use the tools safely, work properly, maintenance and inspection which will make tools more effectively.
- Please check the blind rivets specification and durability on customers side before using it.

1 IMPORTANT NOTICES

- Read this manual carefully before using this tool. Follow instructions in this manual for handling this tool, replacing accessories or replacing parts as needed.
- If you have any questions about this manual, contact the “LOBSTER” dealer where you purchased the tool.
- It is impossible to foresee all potential dangers and describe them in this manual. You must operate this tool paying attention to safety as well as observing the instructions in this manual.
- This manual is translated from Japanese, its original language. It is your own responsibility to achieve a full understanding of the contents of this manual before using the equipment described.
- Lobtex Co., Ltd. has the copyright of this manual. It is prohibited to publish, copy or translate to other language without prior consent.

2 INDEMNIFICATION

- Our warranty does not apply to direct and indirect damages and lost income caused by the misuse, abuse, and unauthorized modification of the tool.
We do not guarantee the strength or quality of blind rivet.
- We do not guarantee any damages and failures caused by any modifications without our written approval.
- We do not guarantee any damages and failures caused by use of parts other than our recommendation.

● IMPORTANT SAFETY INSTRUCTIONS



- ◆ Be sure to read the following Important Safety Instructions carefully and make sure that you understand them thoroughly before using this tool.



- ◆ Always wear protective goggles while using the tool. The rivets may jump out by accident and cause injuries.



- ◆ This is the safety alert symbol. It is used to alert you to potential personal injury hazards. Obey all safety messages that follow this symbol to avoid possible injury or death.
- ◆ These Important Safety Instructions are divided into **⚠ WARNING** and **⚠ CAUTION**. The differences between these two levels are described below.

⚠ WARNING : Indicates a potentially hazardous situation which, if ignored, may result in death or serious injury to the operator.

⚠ CAUTION : Indicates a potentially hazardous situation which, if ignored, may result in moderate injury to the operator or physical damage.

Moreover, failure to follow the instructions marked with the **⚠ CAUTION** symbol or cautions without a

⚠ CAUTION symbol which appear in the text of this manual may also have serious results in some cases. Always be sure to observe the instructions given in the Important Safety Instructions.

- ◆ After reading this manual, keep it in a safe place where it is easily accessible to all users.



WARNING

1. The air pressure should be kept within the range of 0.5 to 0.6 MPa (71 to 85 psi).

- If an air pressure which is greater than this is used, the tool may become damaged, and injury or damage to property may result.

2. Never look into the Nosepiece of the tool, and never point the Nosepiece toward other persons.

- If the tool is used while the cut mandrels are still inside the tool not being ejected, these mandrels may be ejected from the tool's Nosepiece during use and cause serious injury.

3. Always attach the Tank Case Unit before use.

- If you work without attaching the Tank Case Unit, there is a risk that the mandrel of rivet that has been cut is not discharged, and will be clogged inside exhaust pipe, causing a fault of the equipment.
- Also, these mandrels may be ejected from the tool's Nosepiece during use and cause serious injury.

4. Wear protective glasses during use.

- Failure to do so may result in an accident or personal injury in case that a rivet or a piece of cut-mandrels jumps out toward you.

5. Make sure that the tool and the air source are connected securely.

- If the threads of the joints do not match or if the screws are not inserted far enough, the air hose may become disconnected during use and injury may result.
- Use hose bands to securely connect the air hose joint and air hose. If they are not connected securely enough, the air hose may become disconnected during use and injury may result.

6. Turn off the air supply before disconnecting the tool from the air source.

- Compressed air may cause the air hose to whip around, and injury may result.

7. Check that all the tool parts are free from damage before use. Any damaged parts should be repaired before the tool is used.

- If the tool is used while any parts are still damaged, injury may result.
- If the tool is damaged by objects being dropped onto it, for instance, the damaged part may break and accident or injury may result.
- Don't pull and drag the tool by the air hose. It may trigger some damages on the tool body,
- breakage of Rotary Joint or some other defects and lead serious troubles with injuries.

8. If using in elevated locations, use a safety harness, and take care to avoid dropping rivets or the tool itself.

- Accident or injury may result if this practice is not followed.



CAUTION

- 1. Before starting maintenance or disassembling the unit to replace parts, be sure to stop air supply.**
 - Performing maintenance or disassembly with air supplied may cause a part to jump out, oil to squirt out, or the unit to perform unexpected behavior, and may result in an accident or personal injury.
- 2. Tighten the Bleed Plug firmly before use.**
 - If the Bleed Plug is loose or coming off during use, oil may squirt out resulting in an accident or personal injury.
- 3. Do not operate the tool with the Frame Head removed.**
 - Items such as fingers may become caught in the mechanism.
- 4. Do not bring your face close to the exhaust ports.**
 - Pressurized air containing fine particles is discharged from the exhaust ports during use. Keep eyes away from this area.
- 5. Avoid skin contact with substances such as hydraulic oil, lubricating oil and grease.**
 - Such substances may cause inflammation of the skin. If they come into contact with your skin, wash the affected area thoroughly.
- 6. The parts to be used must be those supplied from us or recommended by us. Select and attach parts applicable to your rivet.**
 - Otherwise the unit may not produce maximum performance and may sometimes malfunction resulting in an accident or personal injury.
- 7. Make sure that the workplace is safe, clean and organized.**
 - Accidents can easily occur in untidy workplaces.
 - If the cut mandrels are allowed to fall onto the floor, you may slip on them, and injury may result.
- 8. Avoid uncomfortable postures while working.**
 - You may fall down and injury may result.
- 9. Keep people who are not involved in work away from the workplace.**
 - Accidents or injury may result.
- 10. Maintain the tool with proper care.**
 - Refer to the Instruction Manual for details on replacing parts and attachments, otherwise injury may occur.
- 11. Keep the handgrip always dry and clean, and avoid adhesion of oil and grease.**
 - Otherwise the grip may slip from your hand resulting in falling of the unit.
- 12. Do not leave the floor littered with cut mandrels.**
 - Cut mandrels are dangerous because their ends are sharp. Stepping on them is also dangerous easily causing a slip and fall accident.
- 13. Use the tool carefully and concentrate on correct operation at all times.**
 - Use the tool with proper care, paying full attention to methods of handling and operation and surrounding conditions. Accidents and injury may result if this practice is not followed.
 - Use common sense at all times, otherwise accidents or injury may result.
 - When you are tired, do not use the tool, otherwise accidents or injury may result.
- 14. Ask Lobtex to carry out any repair work required.**
 - Repair work should only be carried out by a qualified technician. Please contact your nearest "LOBSTER" distributor, representative, or direct to Lobtex Co., Ltd., Osaka. If the tool is repaired
 - by someone without the necessary qualifications and experience, the tool may not perform to optimum standards, and accidents or injury may result.
- 15. Do not attempt to modify the tool.**
 - Unauthorized modifications may cause malfunctions which can lead to accidents or injury.
- 16. Only for EU countries, do not dispose of electric tools together with household waste material !**
 - In observance of European Directive 2002/96/EC on waste electrical and electronic equipment and its implementation in accordance with national law, electric tools that have reached the end of their life must be collected separately and returned to an environmentally compatible recycling facility.
- 17. Important information and clue about the use are listed in main body label. When contents cannot read by contamination or by the damage of the label, please order a new label and put it.**
 - The new label could be ordered from us(Lobtex)via distributor.



CAUTION

18. The production date of this product is shown brevity code below the tools.(on page5)
 (Example)year: 20^②0^① month: 1^⑩ → B 0 0 ○○○○

↓ ↓ ↓ ↓
 B 0 0 (Lot No.)

How to check manufactured date

A year/month of manufacture	1	2	3	4	5	6	7	8	9	10	11	12
An English character	A	B	M	N	K	W	T	Y	U	O	L	Z

19. This product is a tool for exclusive use of the professional business. When you are the one who uses this tools for the first time, please receive an instruction from the one who have already used this tools before, also please read the Instruction Manual carefully and understand the content.
- Wear protective goggles or safety glasses.
 - When this product is damaged, please do not use.
20. This product is an exclusive tool for Blind Rivet fastening two boards by riveting. We do not design, manufacture or sell intending to other applications.
21. Please perform regular inspection and maintenance on this machine. As a guideline, inspect fastening every 30,000 blind rivets or once a year, and request repair if any abnormality is suspected.
22. Only persons who are well trained and qualified should use, adjust, and maintain this product.
23. Do not modify the tool. Any modification to the equipment impairs the validity of safety devices, leading to a higher risk to operators.
24. Slip, trips and falls are major causes of workplace injury. Be aware of slippery surfaces caused by use of the tool and also of trip hazards caused by the air line or hydraulic hose.
25. Proceed with care in unfamiliar surroundings. There can be hidden hazards, such as electrical or other utility cables.
26. This machine is not intended for use in potentially explosive atmospheres and is not insulated against contact with electric power.
27. Ensure that there are no electrical cables, gas pipes, etc., which can cause a hazard if damaged by use of the tool.
28. If you experience numbness, tingling, pain or whitening of the skin in your fingers or hands, stop using the tool, inform your employer and consult a physician.
29. Compressed air can cause severe injury.
- Be sure to disconnect the tool from the air supply source when it is not in use or before replacing or repairing it.
 - Never direct air at yourself or anyone else.
28. Always check for damaged or loose hoses and fittings.
- Whipping hoses can cause severe injury.
29. Always make sure there are no damages on hoses and no loose fittings.
30. Do not carry the pneumatic tool by holding the hose.
31. Preventative maintenance should be carried out, after a specified time of operation, a specified number of cycles/operations or a stated number of times per year.
32. When you handle oil or grease, obtain the material safety data sheet (SDS) from the supplier, and follow the described instructions.

NOMENCLATURE

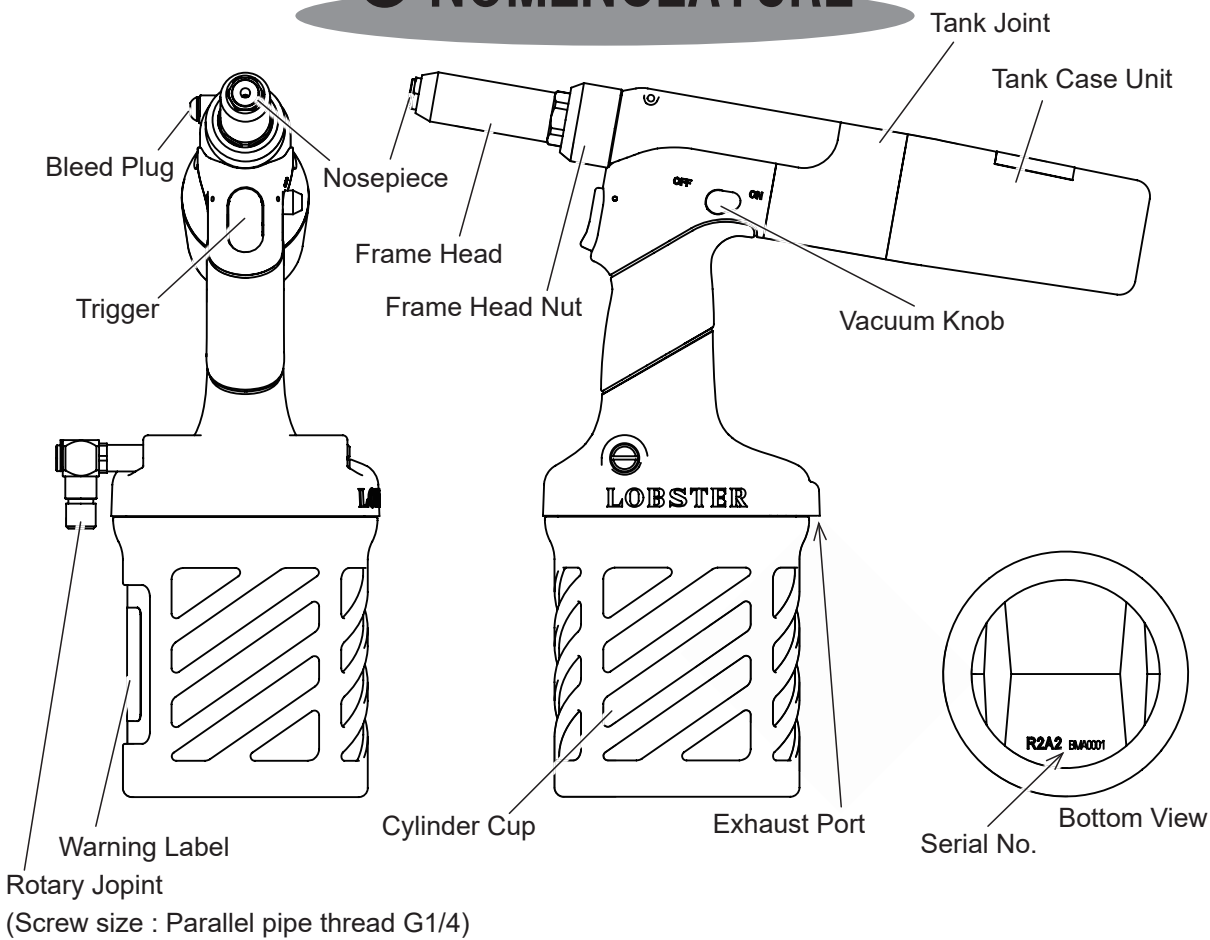

FRAME HEAD INTERNAL PARTS

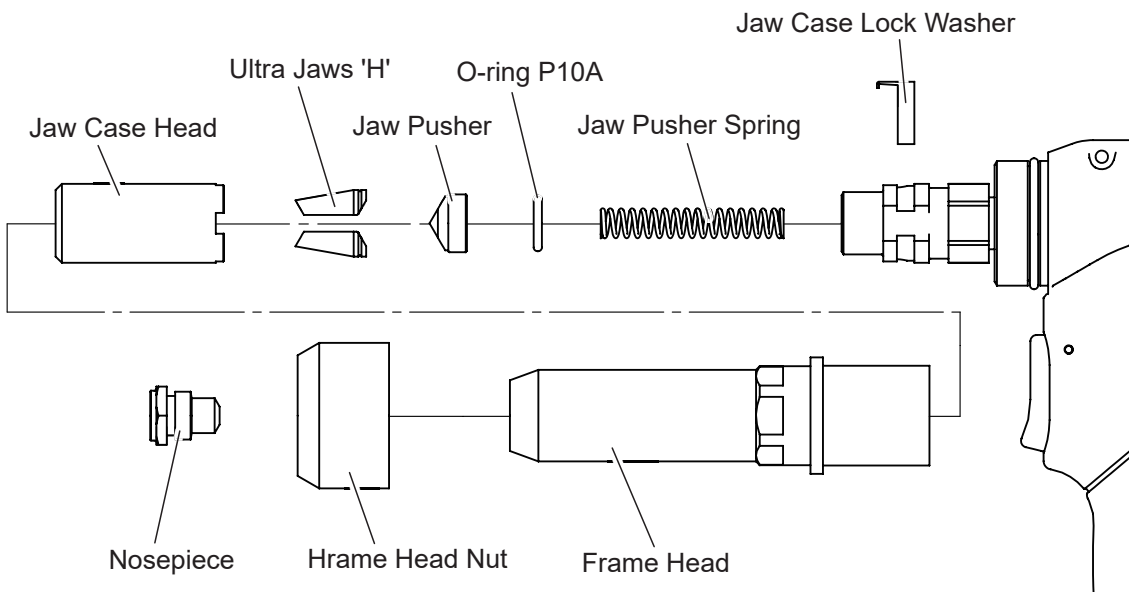

● TECHNICAL DATA

Model No.		R2A2
Weight kg		2.0
Operating air pressure MPa		0.5 ~ 0.6
Dimensions (Length×Height×Width) mm		331×318×143
Air consumption per minute L/min (At air pressure 0.6 MPa)		105(on the occasion of vacuum is working)
Tool stroke mm		25
Traction power at 0.6 MPa		18.5(on the occasion of vacuum is working)
Applicable rivets(rivet diameters) φmm		4.8 · 6.4
Operating environment	Temperature °C	4 ~ 35
	Relative humidity %RH max	80%RH max. (No condensation)
Sound	Pressure level (Lpa)	80 dB
Vibration	Emission value (At air pressure 0.6 MPa)	Less than equal to 2.5m/sec ²
Air intake (Rotary Joint)		Size of screw G1/4 (PF1/4)

- Product specifications and design are subject to change for improvement without notice.
- Weight and dimensions given are standard values. Actual products may differ slightly from the values given.
- The warning label is located on the side of the Cylinder Cup.
- The production date of this product is indicated on the bottom of Cylinder Cup with brevity code. Please refer to the page 5 how to read its brevity code.
- The serial number of this product is indicated on the top surface of Cylinder Cup with numbers.

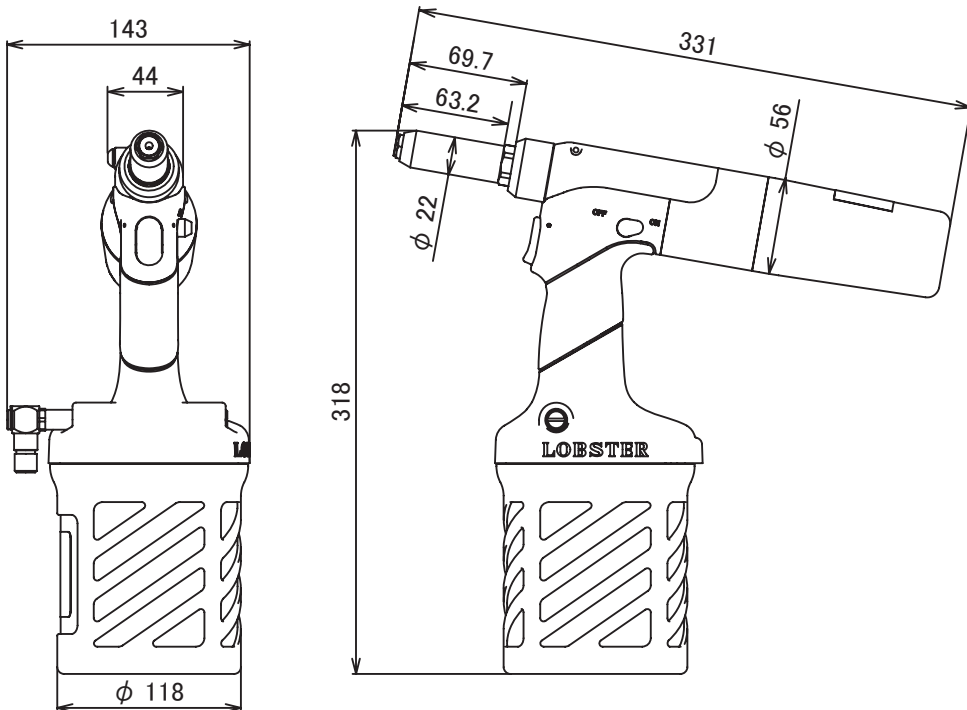

■ Air consumption calculation method ■

Use the following calculation method to obtain the required air consumption, and select the compressor accordingly.

$$\boxed{\text{Required air consumption} = \text{Air consumption per minute}}$$

Make sure that this corresponds to the compressor discharge capacity (per minute).

● PREPARATION BEFORE USE

1 Set the Tank Case Unit to the Tank Joint.

⚠ WARNING

- Always attach the Tank Case Unit before use.
If you work without attaching the Tank Case Unit, there is a risk that the mandrel of rivet that has been cut is not discharged, and will be clogged inside exhaust pipe, causing a fault of the equipment. Also, these mandrels may be ejected from the tool's Nosepiece during use and cause serious injury.

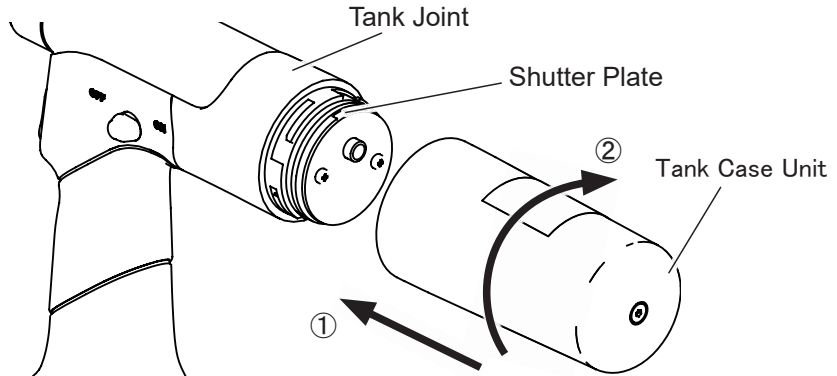

Align the shutter plate with the notch inside the Tank Case Unit, press it against the Tank Joint (①), and turn the Tank Case Unit clockwise (②) to attach it.

2 Replace the nosepiece and Guide Pipe Unit as indicated below to conform to the size of the rivet being used. (Refer to "Replacement of the Nosepiece" on page 13.)

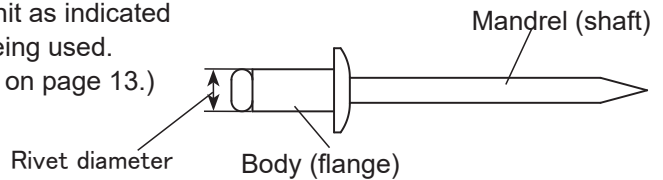

Rivet Dia.	Nosepiece
4.8 mm	4.8 
6.4 mm	6.4 

- Shaded areas indicate parts which are installed in the tool as standard accessories.

IMPORTANT

Be sure to replace the Nosepiece according to the blind rivet size you are using. Even if the mandrel can be inserted into the Nosepiece, if it is the wrong size, it may clog inside.

When using the product after a long period of disuse, please perform maintenance and inspection carefully. (Refer to "Jaw maintenance" on page 11)

Please perform maintenance and inspection and activate the vacuum function before use.

- 3** Set up the compressor, and be sure to install an air filter, air regulator and air lubricator (3-device set) between the compressor and the tool.

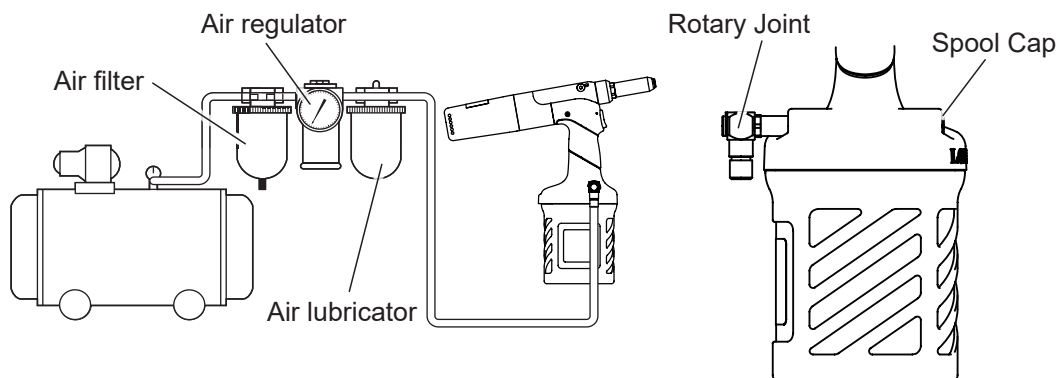

- Adjust the drip-feed amount of the air lubricator to the minimum setting.
- If moisture enters inside of the unit, it may freeze in cold temperature or accelerate degradation of O-rings and packings, resulting in malfunction of the unit. To avoid that, use an air dryer as necessary in addition to an air filter, regulator and an air lubricator (3-device set).
- If you attach the Rotary Joint to the opposite side, remove the Spool Cap and exchange the positions.

- 4** Use the air regulator to adjust the operating air pressure to 0.5 ~ 0.6MPa.

⚠ WARNING

- **The air pressure should be kept within the range of 0.5 to 0.6 MPa**

If an air pressure which is greater than this is used, the tool may become damaged, and injury or damage to property may result.

- If the air pressure is too high, damage to parts may occur. If the pressure is too low, some size of the rivet may not be correctly installed (cut).

● OPERATING THE AIR RIVETER

1 Select a suitable size of rivet for the workpiece to be riveted.

2 Replace the Nosepiece with one which matches the size of the rivet to be used.
(Refer to "Preparation Before Use" on page 8.)

3 Drill a hole of appropriate size
(0.1 to 0.2mm larger than the diameter of the rivet) into the workpiece.



4 Make sure that the Tank Case Unit is set, and turn the Vacuum Knob clockwise to activate the vacuum.
*This tool is designed vacuum will not work unless the Tank Case Unit is attached.
*Do not pull the Vacuum Knob towards you.
The vacuum may not work.

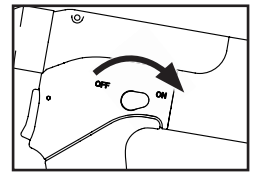

5 After inserting the mandrel (shaft) of the rivet into the Nosepiece.

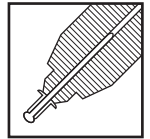

6 insert the head of the rivet into the hole.

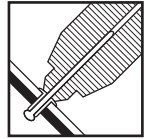

7 Lightly fit the end of riveting tool to the base material. Make sure that there is no space in the base material and other things, and then activate the trigger. The rivet will be installed into the workpiece.

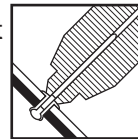

8 Release the trigger. The cut mandrel (shaft) will then be drawn into the Tank Case Unit.
*Make sure that the cut mandrel has been completely removed before proceeding to the next riveting.

9 When the tank is about half full with cut mandrels, Turn the vacuum knob counterclockwise to stop the vacuum, then turn the Tank Case Unit counterclockwise to discard spent mandrel.
*If the tank becomes over half full, cut mandrels may be obstructed by those inside the tank and may not normally be collected, causing them to be left in the ejection pathway. That will result in clogging of cut mandrels and air leakage from the Nosepiece making the unit to be unusable.

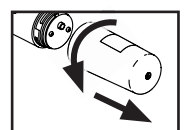
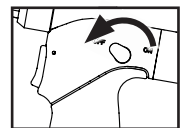

● MAINTENANCE

After long periods of use, debris from cut mandrels and other foreign materials tend to build up in various parts of the tool, and the hydraulic oil level also drops, both of which can lead to operating problems. The tool should be cleaned periodically.

1 Jaw maintenance

- If debris builds up, the jaws will not move smoothly and normal operation will not be possible.
- The jaws should be cleaned on average once every 3,000 riveting operations.

⚠ CAUTION

- **Before starting maintenance or disassembling the unit to replace parts, be sure to stop air supply.** Performing maintenance or disassembly with air supplied may cause a part to jump out, oil to squirt out, or the unit to perform unexpected behavior, and may result in an accident or personal injury.
- **Jaws are consumable items and must be replaced periodically.** This tool uses Ultra Jaws that are highly durable. When replacing, please order "Ultra Jaws "H".
- **Never loosen the Bleed plug for any purpose other than refueling.** Hydraulic oil may leak or air may get in to the tool.
- **Do not operate the tool with the Frame Head removed.** Items such as fingers may become caught in the mechanism.

1 Turn off the air supply.

2 Loosen and remove the Frame Head Nut and remove the Frame Head.

3 Remove the Jaw Case Lock Washer in the direction shown in the illustration, and loosen and remove the Jaw Case.

4 Remove the Jaw Pusher Spring, Jaw Pusher, and Jaws.

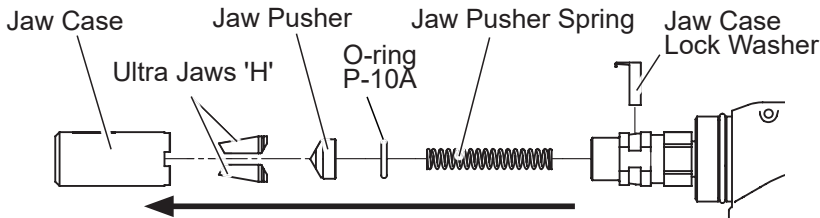
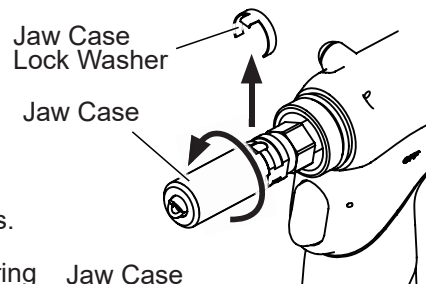
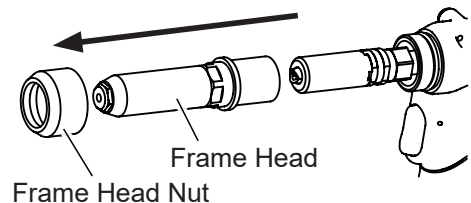

⚠ CAUTION

- Never loosen the Jaw Case Joint and Jaw Case Lock Nut. Doing so readily exposes parts inside the air riveter to damage.
- When these parts got loose, contact your nearest distributor for repair since it needs to be tightened by specified torque by using specified tool.

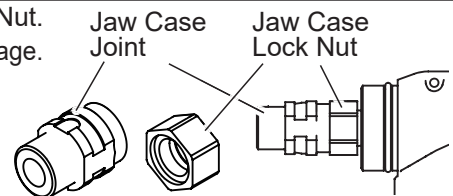

DISASSEMBLY

英語 / ENGLISH

CLEANING

- 5** Using a brush or the like, clean parts. In particular, carefully clean the following areas.
- Back of the Frame Head
 - Toothed section of the Jaw
 - Sliding section between the Jaw Case and the Jaw

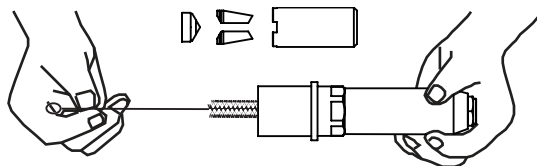

- 6** Assemble the air riveter in the opposite order in which it was disassembled. Apply lubricant oil to the back of the Jaws (conical surface) and the inside of the Jaw Case (conical surface), and put the Jaws, Jaw Pusher, O-ring, Jaw Pusher Spring into the Jaw Case in this order.

Tighten the Jaw Case to the end. From there, return it to the position where the upper notch and the lower notch meet each other for the first time, and set the Jaw Case Lock Washer.

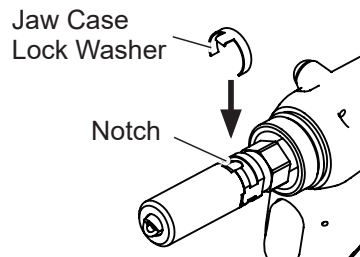
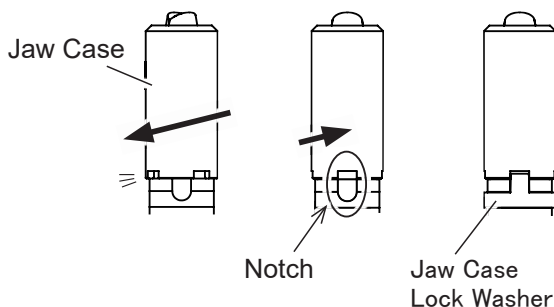
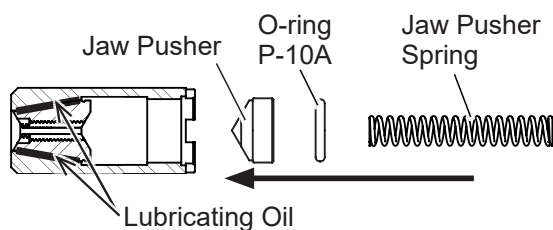

*Jaw Case, Ultra Jaws 'H', Jaw Pusher, O-ring, Jaw Case, and Jaw Pusher Spring are consumable items. Replace them on a regular base.
 *For lubricating oil, use the accessory part or the separately sold "LOBSTER" lubricating oil JO-50.

- 7** Insert the Frame Head and tighten the Frame Head Nut to fasten the Frame Head.
 *To prevent scratching from occurring, apply lubricant to the screw of the Frame Head Nut.

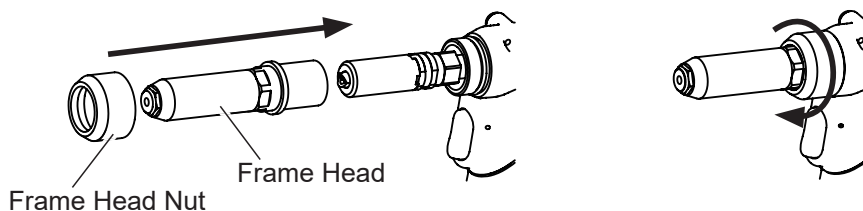

RE-ASSEMBLY

2 Replacement of the Nosepiece

- * If the Nosepiece is damaged, replace it with a new one.
- * If you change the rivet size, replace with an applicable Nosepiece.

DISASSEMBLY

- 1 Turn off air supply.
- 2 Remove the Nosepiece from the Frame Head using a wrench or spanner.

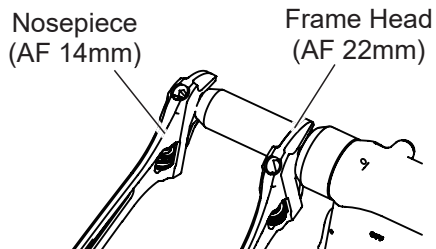

RE-ASSEMBLY

- 3 Firmly set a Nosepiece applicable to the rivet size to the Frame Head
- * Please check periodically whether there is any slack of a Nosepiece during work.
 - * If you work after the Nosepiece is loosened, damage to the parts may occur.

3 Oil Supply

⚠ CAUTION

- Customers themselves do not need to oil the air riveter in principle. To lubricate parts, however, use the B29624 oiler (syringe unit, optionally available), and lubricate parts with Ebi-brand hydraulic oil B10012 (optionally available) as explained in the following steps. If the stroke is inadequate immediately after lubricating with hydraulic oil, the seal may be worn or some other issue may exist. In such case, have the air riveter serviced.
- Prevent oils such as hydraulic oil, lubricating oil, and grease from contacting skin and eyes. This may cause irritation. If contacted, wash completely from the contacted area.
- Do not lubricate the air riveter with the Cylinder Cup removed.

- * Note that hydraulic oil does not come standard with an oiler.

DISASSEMBLY

- 1 To remove the Bleed Plug and the Seal Washer, loosen the Bleed Plug with a hexagonal wrench (width across flats: 4 mm) or the like, with the air riveter placed horizontally so that the Bleed Plug is to the upper side.

- * When you loosen the Bleed Plug, hydraulic oil may spew vigorously. Therefore, loosen the Oil Retaining Screw slowly at first.
- * Hydraulic oil coming from the air riveter may be black. This is not abnormal. As long as hydraulic oil is not mixed with air, metal powder, or dust, you can use it without a problem.
- * When a large amount of air mixes with hydraulic oil, the seal can wear. In such case, have the air riveter serviced.

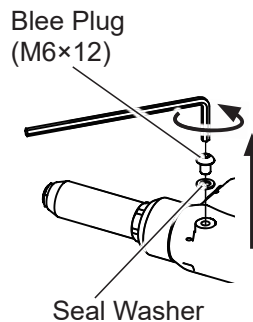

- 2 Remove the O-ring (P-6) at the tip of the oiler, and attach the Seal Washer that was removed in step 1, to the tip of the oiler instead of the O-ring.

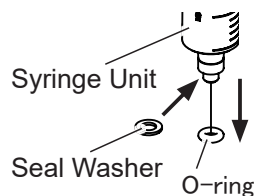

⚠ CAUTION

- Do not lubricate the air riveter with the Frame Head Nut and frame head removed. Doing so may result in an improper amount of hydraulic oil and cause trouble with the air riveter.

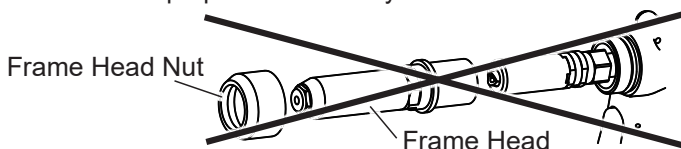

- 3** Attach the oiler containing the hydraulic oil to the oiling port in the air riveter (the part to which the Bleed Plug was attached).

- * Make sure that the Seal Washer is attached to the tip of the oiler. Without a Seal Washer in place, air can mix with the hydraulic oil during oiling or prevent oil from being sufficiently supplied.
- * If air (in the form of air bubbles) is found inside the oiler, point the tip of the oiler upward and slowly insert the plunger to purge air, and then attach the oiler to the air riveter.
- * When you purge air from the oiler, hydraulic oil may spew from the tip of the oiler. Keep your face away and cover the tip of the oiler with cloth or the like while purging.
- * Be careful not to allow a gap to form between the oiler and the air riveter. Gapping may allow air to mix with the hydraulic oil.

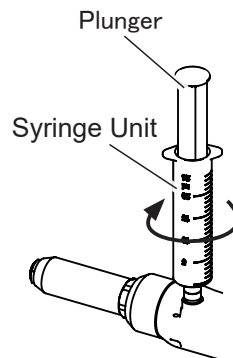

- 4** Insert the plunger of the oiler and inject the hydraulic oil into the air riveter.

- 5** Insert the plunger of the oiler several times and make sure that the air riveter is adequately filled with hydraulic oil.

- * When the air riveter is adequately filled with hydraulic oil, the plunger returns after being inserted and then released.

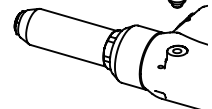
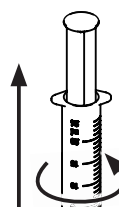
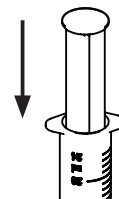

⚠ WARNING

- Do not oil the air riveter in ways other than that described in this instruction manual. Doing so may supply an excessive amount of hydraulic oil, damage parts and cause injuries .
- Do not try forcing an excessive amount of oil into the air riveter.

- 6** Loosen the oiler and remove it from the air riveter. Remove the Seal Washer from the tip of the oiler.

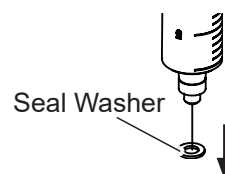

7 Attach the Bleed Plug and Seal Washer to the air riveter using a hexagonal wrench (width across flats: 4 mm).

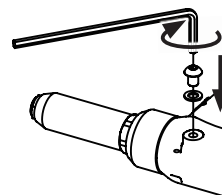

8 Wipe off hydraulic oil adhering to the main body or spilling out before use.

* During disassembly/assembly, be careful to prevent cutting dusts of metal and other objects from getting into the hydraulic oil and Air Cylinder.

● STORAGE

- Store in a place which is well-ventilated and free from excessive dust and humidity, and where there is no danger that tool will fall.
- If the tool will not be used for a long period of time, inspect the parts as shown in “Maintenance” on pages 11 to 14 prior to storing the tool.
- To increase the working life of the tool, it is recommended that you perform the periodic overhauls. Contact the place of purchase or your nearest “LOBSTER” dealer for any overhauls and repair work required. (A charge will be made for this service.)

● ORDERING PARTS

Indicate the tool model, part name, code no. and quantity as shown below when ordering.

Model	Part name	Code No.	Qty.
R2A2	Ultra Jaws 'H'	10493	1
R2A2	Nosepiece 4.8	10216	1

* When parts are modified for improvement, the older parts are kept in stock for a period of five years.

● EXPLODED VIEW

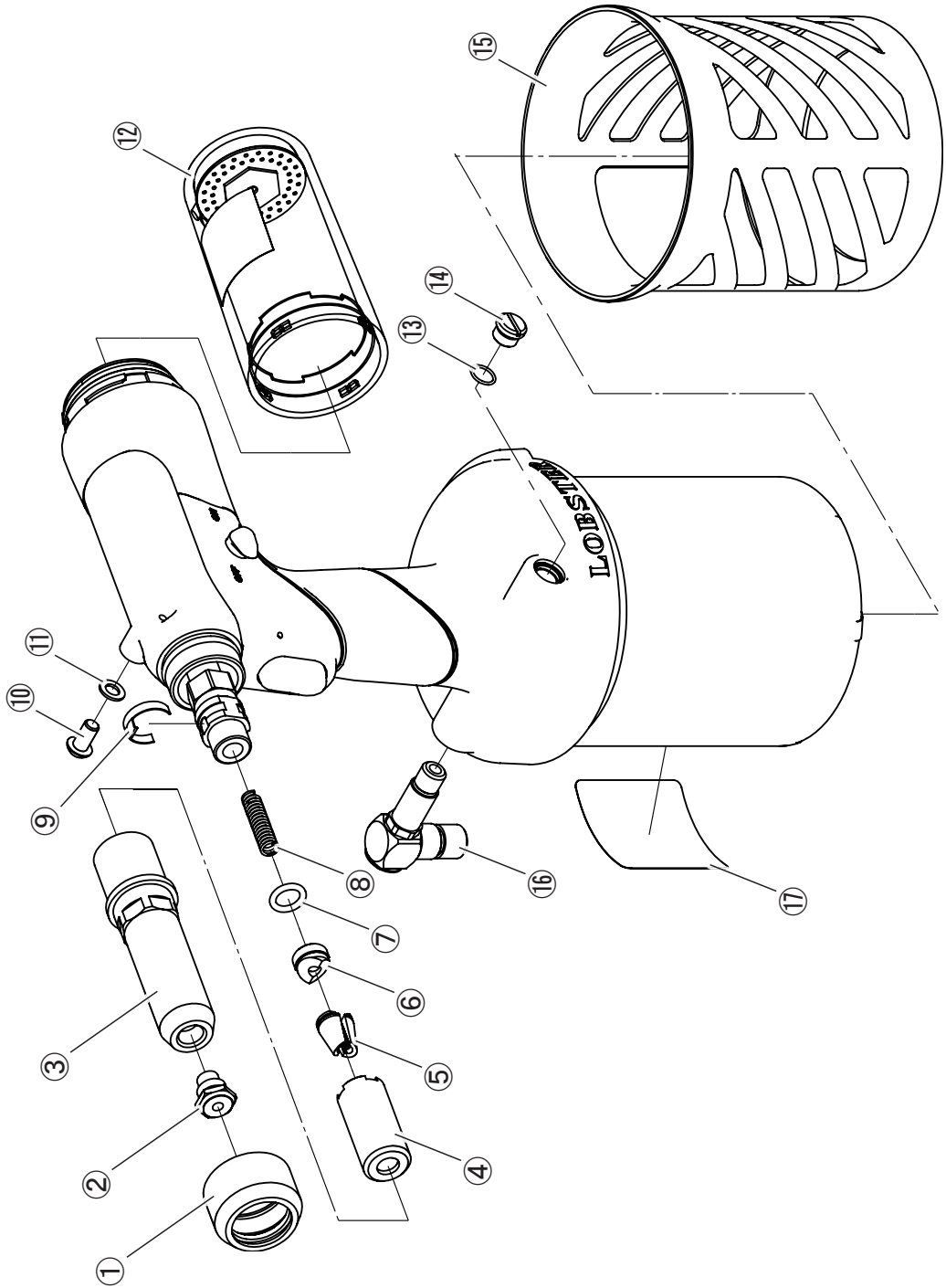

● PARTS LIST

Index No.	Part name	Code No.	Material
1	Frame Head Nut	70040	Aluminum
②-B	Nosepiece 6.4	10226	Steel
3	Frame Head	70039	Steel
④	Jaw Case	63990	Steel
⑤	Ultra Jaws 'H'	10493	Steel
⑥	Jaw Pusher	63991	Steel
⑦	O-ring P-10A	10337	Rubber
8	Jaw Pusher Spring	63992	Steel
9	Jaw Case Lock Washer	63959	Steel
10	Bleed Plug (M6×12)	63213	Steel
11	Seal Washer	63209	Rubber
⑫	Tank Case Unit	70057	①
13	O-ring S-8	14475	Rubber
14	Spool Cap	69495	Aluminum
15	Cylinder Cup Cover	69992	Rubber
16	Rotary Joint Unit	70042	②
17	Warning Label	61075	Plastic, Paper

Material

① : Plastic, Steel,
Stainless, Sponge, Paper

② : Aluminum, Steel, Rubber

Accessory parts

Index No.	Part name	Code No.	Material
②-A	Nosepiece 4.8	10216	Steel
-	Lubricating Oil	-	Plastic, Oil

* Parts with circled Index No. are consumable parts. They should be replaced periodically.

Separately sold

Index No.	Part name	Code No.	Material
-	Priming Pump(SyringeUnit)	29624	Plastic
-	"LOBSTER" hydraulic oil	10012	Plastic, Oil
-	"LOBSTER" lubricant oil JO-50	889	Plastic, Oil

● TROUBLE SHOOTING

If a problem occurs, check the followings. If the problem persists after checking the items in the table below, contact your nearest "LOBSTER" dealer or direct to us.

In making any enquiries about this product or requests for repair work, first check the troubleshooting items below, and then make a note of the model number, the usage conditions and the trouble symptoms in as much detail as possible. If you can provide this kind of information, it will contribute to reducing the amount of time required for delivery or repairs to be completed.

Trouble	Couse	Countermeasure
The rivet does not go in, or the cut mandrel does not come out after riveting.	1 Wrong type of Nosepiece or Guide Pipe Unit.	Replace with the correct part which matches the rivet size. (Refer to pages 8.)
	2 Nosepiece or Frame Head is loose.	Use a spanner or similar to tighten securely. (Refer yo page 13)
	3 Jaw Case is incorrectly assembled.	Check the assembly procedure of parts inside the Jaw Case. (Refer to page 11,12.)
	4 Contact surface between Jaws and Jaw Case are not smooth. (friction).	Clean the Jaws and the inside of Jaw Case, and apply "LOBSTER" brand lubricant oil to the back of Jaws. (Refer to page 11,12.)
	5 Oil filling was not performed correctly, so that there is excess hydraulic oil inside the tool.	Loosen the Bleed Plug to allow the excess hydraulic oil to drain out. (Refer to pages 13,14).
	6 Mandrels clog up the Jaw Pusher or the machine.	Eliminate the mandrels clogging in the Jaw Case or inside of the riveter. (Refer to page 11,12.)
Rivet working does not complete with one trigger operation	1 The rivet length is not correct for the workpiece thickness.	Use rivet which match the workpiece thickness.
	2 Compressor air pressure is incorrect.	Increase air pressure. (By making air pressure more than maximum 0.6 MPa or more will lead to damage to parts. If the rivet does not break even with the maximum air pressure, that rivet cannot be used.) (Refer to page 9.)
	3 Jaw Case is incorrectly assembled.	Check the assembly procedure of parts inside the Jaw Case. (Refer to page 11,12.)
	4 Jaws are worn.	Replace the Jaws. (Refer to page 11,12.)
	5 The Jaw Pusher Spring has been worn.	Replace Jaw Pusher Spring (Refer to page 11,12.)
	6 Insufficient hydraulic oil, causing a shorter stroke.	Add hydraulic oil. (Refer to pages 13,14.)
Piston does not operate, or returns very slowly, or operation is not smooth.	1 Insufficient and excess pressure of supplied air.	Adjust to obtain an appropriate pressure of supplied air. (Refer to page 9.)
The suction power is weak and the cut mandrels (shafts) cannot be drawn out.	1 Insufficient turning of Vacuum Knob.	Turn the Vacuum Knob until it stops. (Refer to page 10.)
	2 Too many cut mandrels in the tank.	Remove the Tank Case Unit and discard the cut mandrels. (Refer to page 10.)
	3 Cut mandrels clog in the machine.	Remove the cut mandrels. (Refer to page 11, 12.)
	4 Vacuum Knob is pulled towards you.	Push the Vacuum Knob.

WARRANTY & SERVICE

LOBSTER[®] WARRANTS THAT GOODS COVERED BY THIS MANUAL WILL CONFORM TO APPLICABLE SPECIFICATIONS AND DRAWINGS AND THAT SUCH GOODS WILL BE MANUFACTURED AND INSPECTED ACCORDING TO GENERALLY ACCEPTED PRACTICES OF COMPANIES MANUFACTURING INDUSTRIAL TOOLS. THERE ARE NO WARRANTIES WHICH EXTEND BEYOND THE FOREGOING.

THE LIABILITY OF LOBSTER[®] ON PARTS FOUND TO BE DEFECTIVE IS LIMITED TO RE-WORK OR THE REPLACEMENT OF SUCH GOODS AND IN NO CASE TO EXCEED THE INVOICE VALUE OF THE SAID GOODS. UNDER NO CIRCUMSTANCES WILL LOBSTER[®] BE LIABLE FOR DAMAGES OR COSTS INCURRED BY THE BUYER OR SUBSEQUENT USER IN REPAIRING OR REPLACING DEFECTIVE GOODS.

ROUTINE MAINTENANCE AND REPAIR OF LOBSTER[®] RIVET TOOLS CAN BE PERFORMED BY AN AVERAGE MECHANIC. HOWEVER, IF YOU HAVE A LOBSTER[®] RIVET TOOL THAT IS IN NEED OF MAJOR REPAIR WE RECOMMEND THAT IT BE SENT DIRECTLY TO US POSTAGE PAID FOR SERVICE AT A REASONABLE CHARGES.

MANUFACTURER

LOBTEX CO., LTD.

OSAKA, JAPAN

MEMO

A series of 20 horizontal dotted lines for writing a memo.